



### Features:

- 100 Lumens per Watt
- Revolutionary heat sink design for superior heat management
- Polycarbonate lens provides superior light distribution
- Adjustable beam angle
- Power Factor >0.9
- 0-10V Dimming available
- Modular design with removable driver
- 5 year Warranty
- Operation temperature -30°C to 50°C/ -22°F to 122°F

- Available in 3000K, 4000K, 5000K, and 5700K
- IP65 ingress protection-rated for wet locations

### Applications:

- Landscape Illumination
- Parking Lots
- Sports lighting
- Signage

### Ordering Information:

Ex. FL-10L-50K-A3-UL-SL



#### Model

FL = Flood

#### Lumen Package

3L= 3,124  
 5L= 4,926  
 8L= 7,834  
 10L= 9,954  
 14L= 14,476  
 22L= 21,667  
 29L= 28,666  
 40L= 40,630  
 60L= 59,145

#### CCT

30K = 3000K  
 40K = 4000K  
 50K = 5000K  
 57K = 5700K

#### Beam Angle

A3

#### Voltage

UL= 120-277V

#### Color

SL = Silver  
 DB = Dark Bronze  
 BL = Black  
 WH = White  
 GR = Green

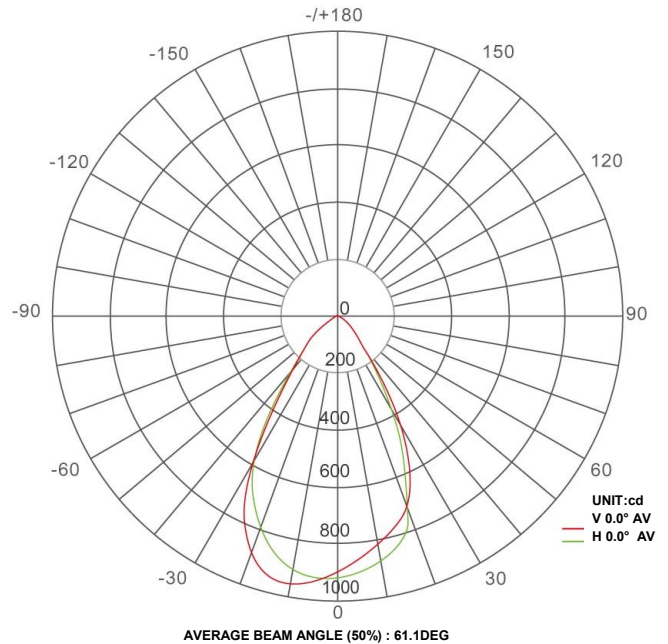
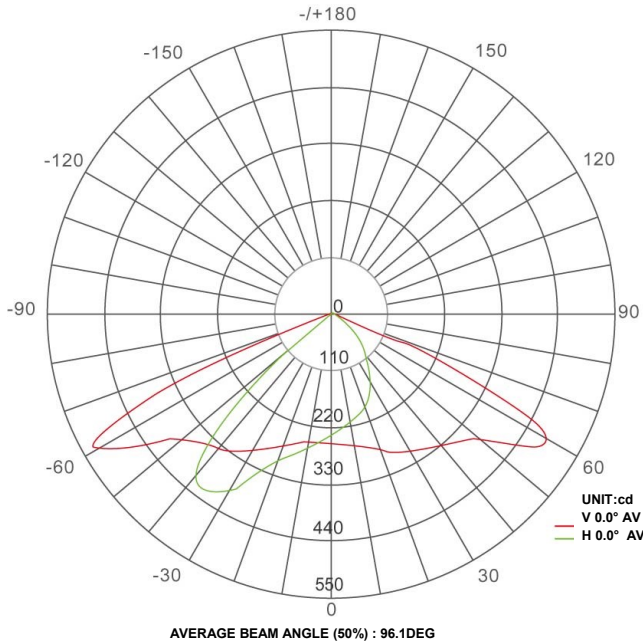
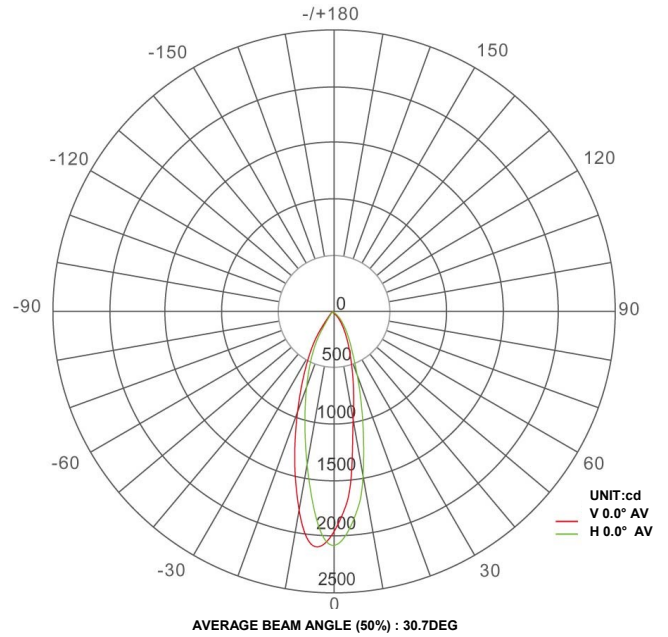
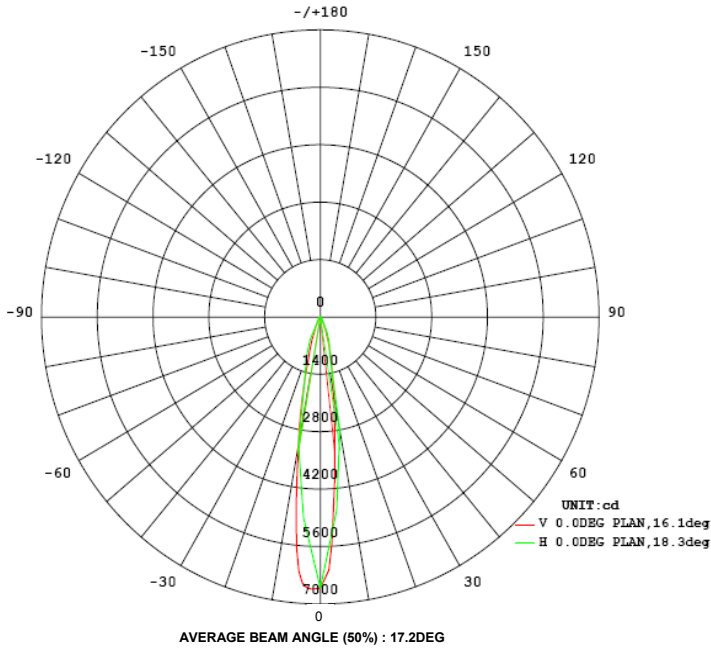

## INSTALLATION INSTRUCTIONS

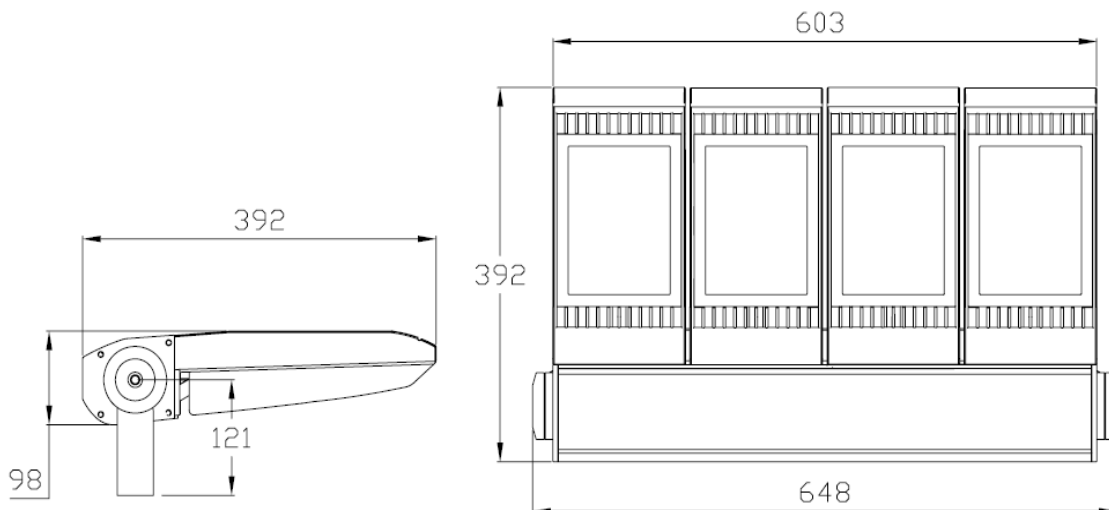
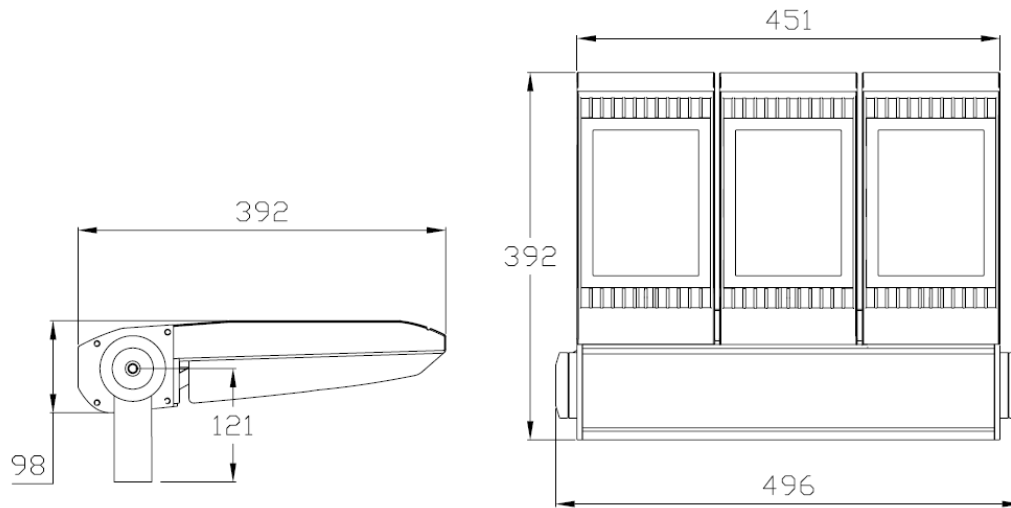
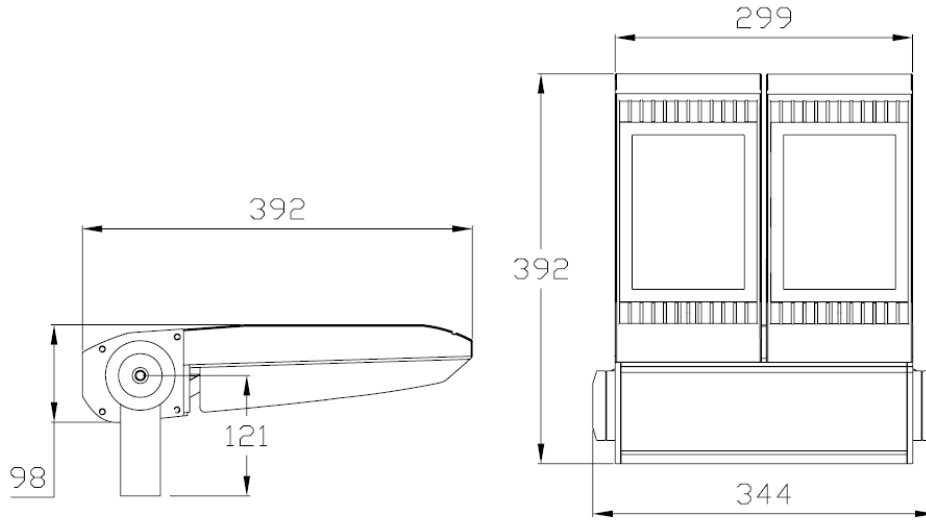

## INSTALLATION INSTRUCTIONS CONTINUED

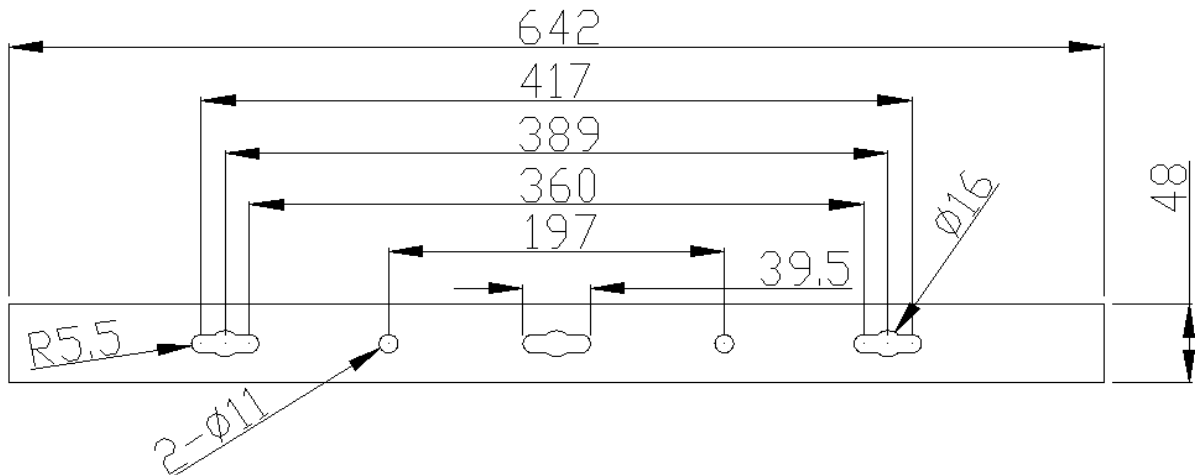
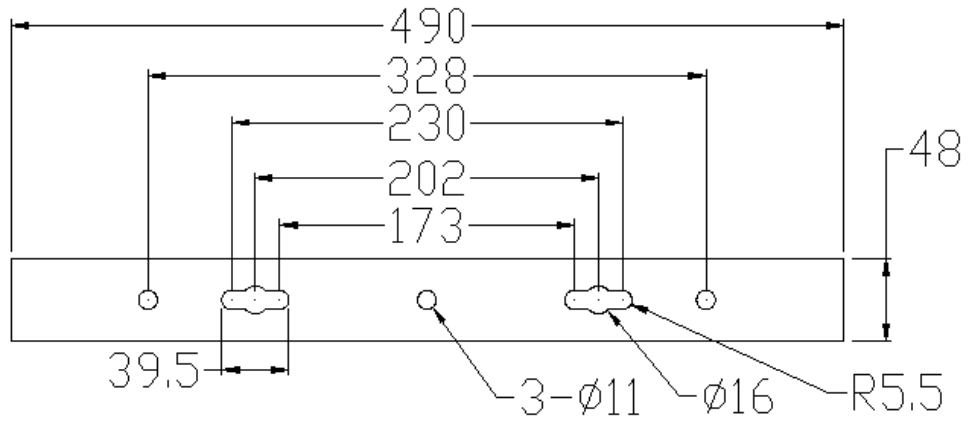
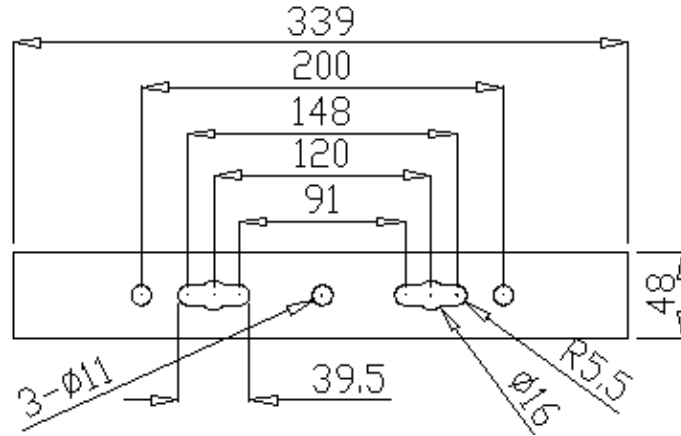

## INSTALLATION INSTRUCTIONS CONTINUED

1. Loosen m10 screw using 8mm Allen Wrench

2. Adjust bracket to desired angle

3. Tighten screw

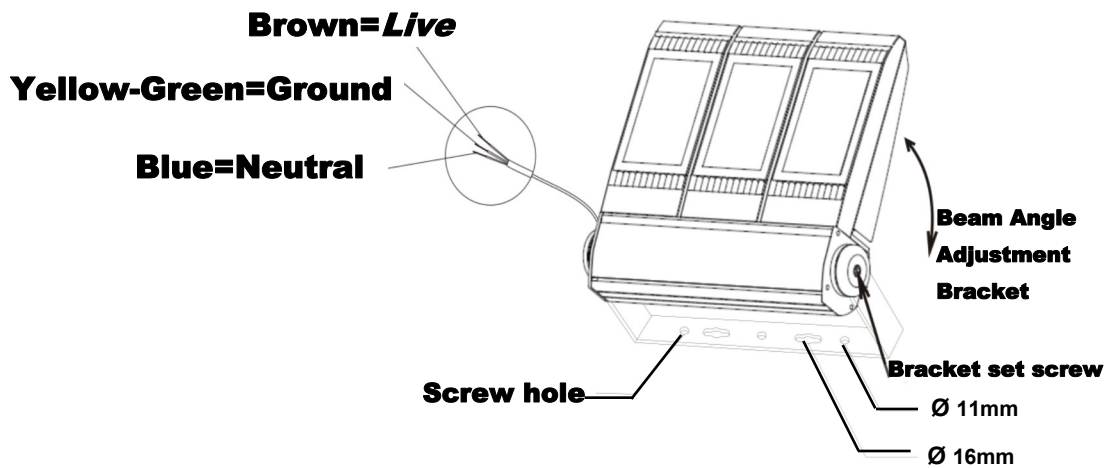
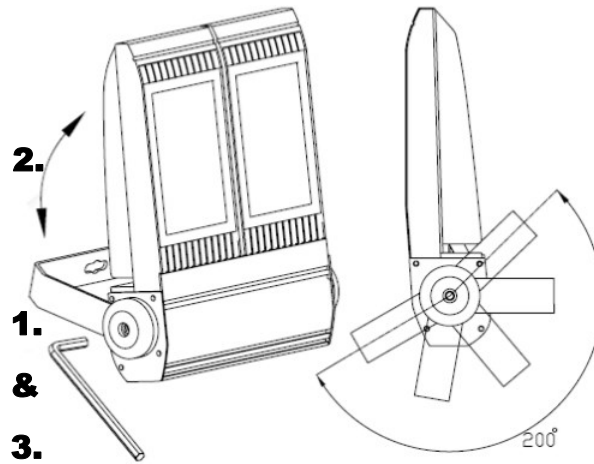

- Improper installation may void warranty. Follow all installation instructions
- 5-Year warranty from date of purchase
- To prevent electrical shock, cut off power before installation
- Avoid exposure to corrosive gases
- Ensure installation site can support weight of luminaire
- Do not cover luminaire
- For safe operation luminaire must be properly grounded